

Instructions - Instrucciones - Anweisungen - Istruzioni - Instrukcje -  
 Instructies - Instruções - Utasítások - Инструкція - Οδηγίες - Instruktioner -  
 Pokyny - Instructiuni - Instrukcija - Instrukcija - Eeskiri - Instrukcie - Navodila -  
 Upute - Instrukcije

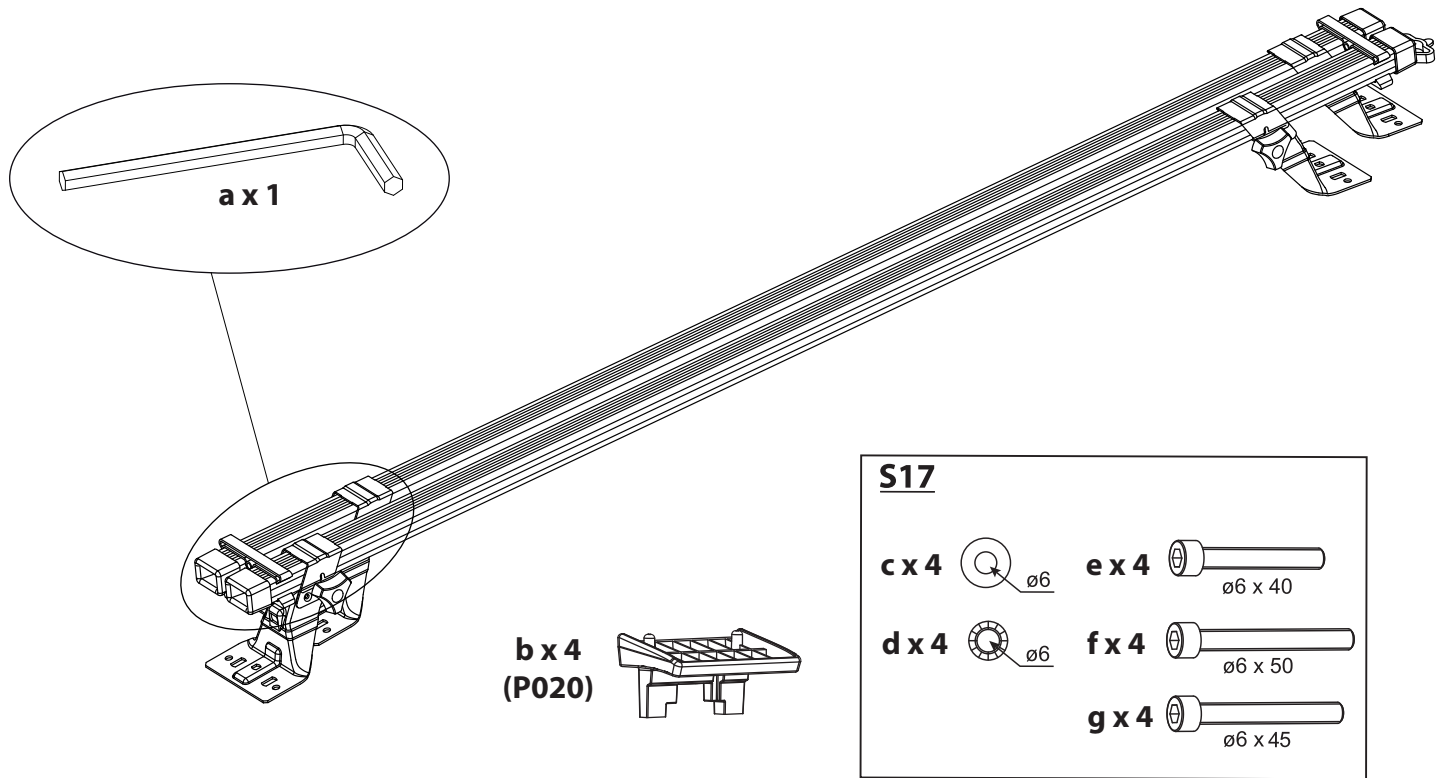

## SUPRA 124

AUTOMAXI



INTERNATIONAL  
STANDARD

**ISO 11154-1**

10/1995

FRENCH  
STANDARD

**NFR 18-903**

12/1995

**3,5 kg**

- FRA** Garder cette notice pour les utilisations futures.
- GBR** Keep these instructions for future use.
- DEU** Die Anleitung zur späteren Benutzung aufbewahren.
- ITA** Conservare queste istruzioni per ogni ulteriore consultazione.
- ESP** Guardar este manual para futuras utilizaciones.
- POL** Zachować instrukcję w przypadku użytkowania w przyszłości.
- NLD** Bewaar deze gebruiksaanwijzing voor toekomstige raadpleging.
- PRT** Guardar este manual para as utilizações futuras.
- HUN** Őrizze meg ezt a használati utasítást későbbi felhasználás céljából.
- RUS** Сохраните эту инструкцию для дальнейшего пользования.
- GRC** Φυλάξτε αυτό το εγχειρίδιο οδηγιών για μελλοντικές χρήσεις.
- DNK** Gem denne vejledning til senere brug.
- CZE** Uschovejte návod pro pozdější použití.
- ROM** Păstrați instrucțiunile pentru consultarea lor ulterioară.
- LTU** Saglabājiet šo instrukciju turpmākai lietošanai.
- LVA** Saugokite šią instrukcijā, kad atteityje galėtumėte ja pasinaudoti.
- EST** Hoidke need juhised edaspidiseks kasutuseks alles.
- SVK** Tento návod si uchovajte pre ďalšie použitie.
- SVN** Sačuvajte ovaj priručnik za buduću upotrebu.
- HRV** Čuvati ove upute za daljnju uporabu.
- YU** Čuvajte instrukcije za dalju upotrebu.









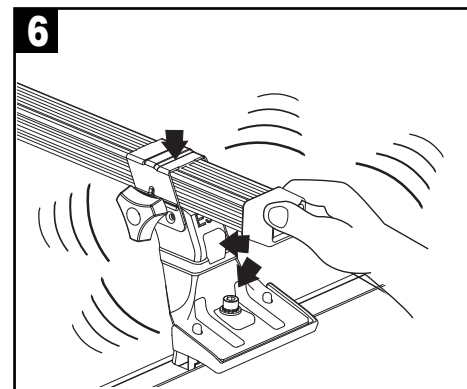
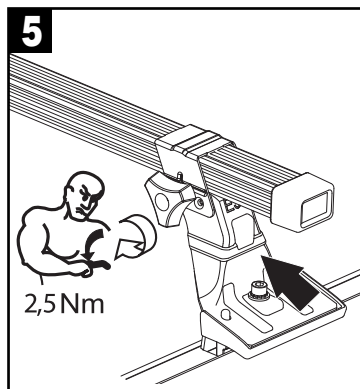
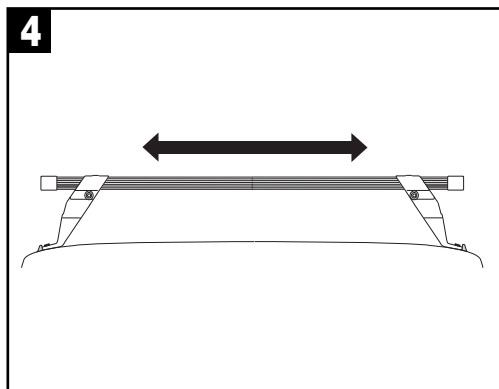
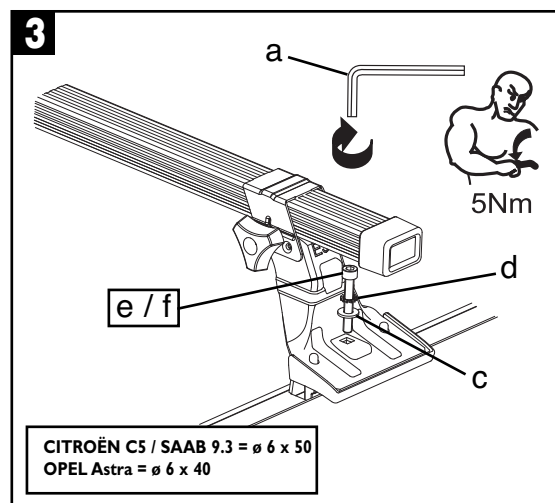
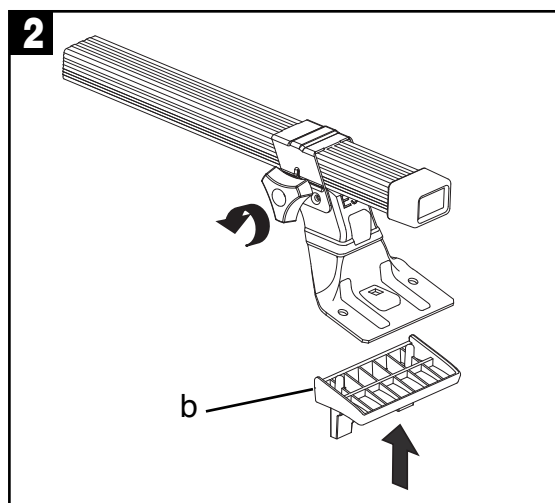
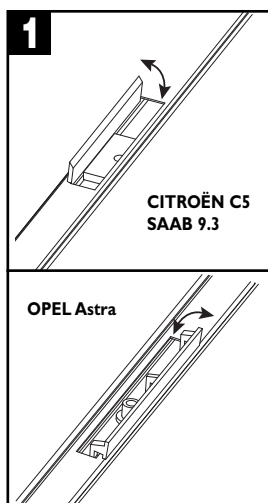



**AUTOMAXI  
INTERNATIONAL**

Z.I Nord - 24 Rue Claude Bernard - CS 61768  
 35417 Saint Malo Cedex - France  
 Tél : 33 (0) 2 99 21 12 70  
 Fax : 33 (0) 2 99 21 12 71  
[www.automaxi.fr](http://www.automaxi.fr)

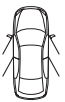
**Montage sur véhicule - Fitting on vehicles - Montagen auf Fahrzeugen -  
 Montaggio su veicoli - Colocación en vehículos - Montowanie na pojazdach -  
 Montage op voertuigen - Montagens em veículos - Felszerelés gépjárműre -  
 Монтаж на автомобиль - Τοποθέτηση στο όχημα - Montage på køretøjer -  
 Montáž na vozidlo - Montaj pe vehicul - Montavimas ant transporto priemonės -  
 Transporta līdzekļa montāža - Sõidukitele paigaldamine - Upevnenie na vozidlá -  
 Oprema na vozilih - Ugradnja na vozilima - Ugradnja na vozilima**



**Les barres de toit ne doivent pas être utilisées sur des véhicules autres que spécifiés -  
 Appropriate for vehicle - Verwenden sie fur fahrzeug - Serve a veiculo -  
 Convienne para vehiculo - Pasujena samochod - Geschikt voor voertuig -  
 Appropriare per vehicule - Megfelelő gépjármű - Подходит для автомобилей -  
 Για το οχημα para - Egnert til køretøjer - Vhodné do vozidel -  
 Convenabil pentru vehicul - Tinka transporto priemonei - Piemērots  
 transportlīdzekliem - Sobib sõidukile - Vhodné pre vozidlo -  
 Primerno za vozilo - Podesno za vozilo - Podesno za vozilo**

											
<b>CITROËN</b>				<b>SAAB</b>							
C4	3/5	04→	75	9.3 <sup>(1)</sup>	5	10/02→	75				
<b>OPEL</b>											
ASTRA III <sup>(1)</sup>	3/5	03/04→	75								

(1) = Sauf break - Except station wagon/estate - Außer Kombi - Salvo break - Salvo break - Z wyjątkiem break - Behalve stationcars - Excepto break - Kombit kivéve - За исключением автомобилей с кузовом "универсал" - Χωρίς break - Undtagen stationcar - kromè vozù kombi - Färã station wagon - Išskyrus universalus - Izņemot daudzvietīgas vieglās automašīnas/īpašumu - V.a universaal - Okrem verzie kombi - Razen karavana - Izuzev karavana - Osim karavana.