

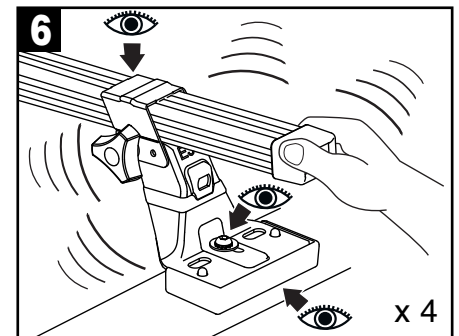

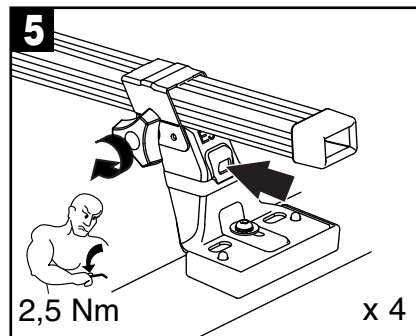

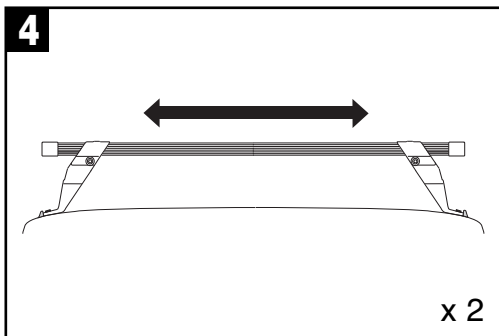

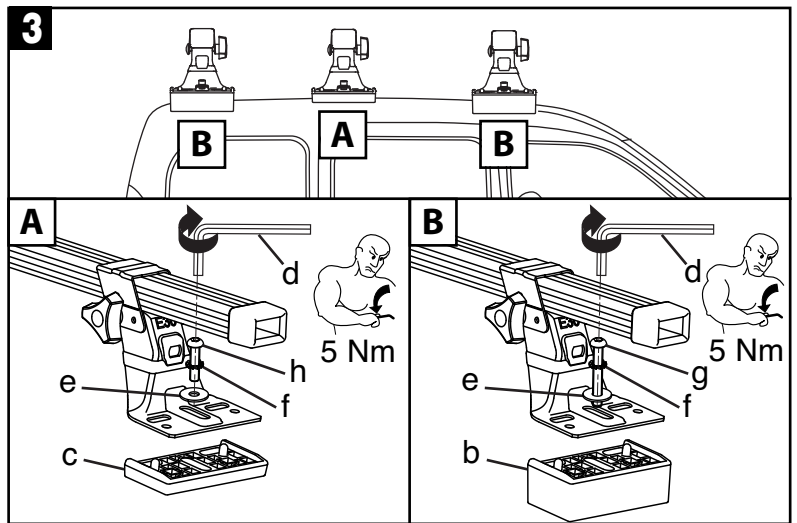

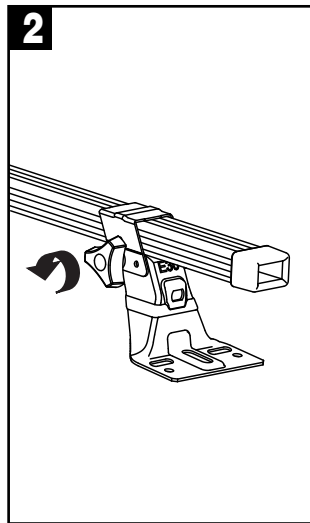
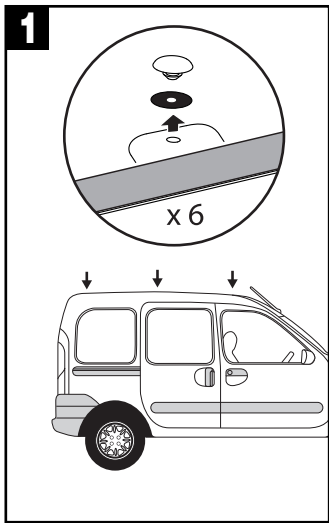



**Montage sur véhicule - Fitting on vehicles - Colocación en vehículos -
 Montagen auf Fahrzeugen - Montaggio su veicoli - Montowanie na pojazdach -
 Montage op voertuigen - Montagens em veículos - Felszerelés gépjárműre -
 Монтаж на автомобиль - Τοποθέτηση στο όχημα - Montage på køretøjer -
 Montáž na vozidlo - Montaj pe vehicul - Montavimas ant transporto priemonės -
 Transporta līdzekļa montāža - Sõidukitele paigaldamine - Upevnenie na vozidlá -
 Oprema na vozilih - Ugradnja na vozilima - Ugradnja na vozilima**

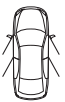

**Les barres de toit ne doivent pas être utilisées sur des véhicules autres que spécifiés -
 Appropriate for vehicle - Verwenden sie fur fahrzeug - Serve a veiculo -
 Convieni para vehiculo - Pasujena samochod - Geschikt voor voertuig -
 Appropriare per vehicule - Megfelelő gépjármű - Подходит для автомобилей -
 Για το οχημα para - Egnæt til køretøjer - Vhodné do vozidel -
 Convenabil pentru vehicul - Tinka transporto priemonei - Piemērots
 transportlīdzekļiem - Sobib sõidukile - Vhodné pre vozidlo -
 Primerno za vozilo - Podesno za vozilo - Podesno za vozilo**

   	   	   
FIAT DOBLO 3/5 ⁽²⁾ 01→ 100		

(2) = Véhicule sans barres longitudinales d'origine - Vehicle without original longitudinal bars - Fahrzeuge ohne original-dachreling - Veicoli senza barre longitudinali originali - Vehículo sin barras longitudinales de origen - Samochód bez oryginalnych relingów - Voertuig zonder originele longitudinale stangen - Veículo sem barras longitudinais de origem - Gyárilag hosszirányú rudak nélkül szerelt gépjármű - Автомобиль без продольных дуг, предусмотренными моделью - Όχημα χωρίς διαμήκεις μπάρες από εργοστασιακή κατασκευή - Køretøj uden originale bjælker på langs - Vozidlo bez původních postranních tyčí - Vehicul fără bare longitudinale originale - Transporto priemonė be originalių lonžerou - Satiksmes līdzeklis bez oriģinālā gareniskā stienstieģrojuma - Sõidukid ilma esialgsете pikivarrasteta - Vozidlo bez pôvodných pozdĺžnych lišt. - Vozilo brez originalnih vzdolžnih drogov - Vozilo bez originalnih uzdužnih šipki - Vozilo bez originalnih uzdužnih šipki.