

2

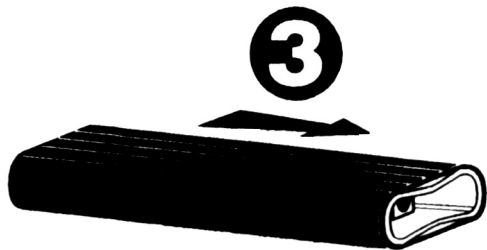

FIAT DOBLO

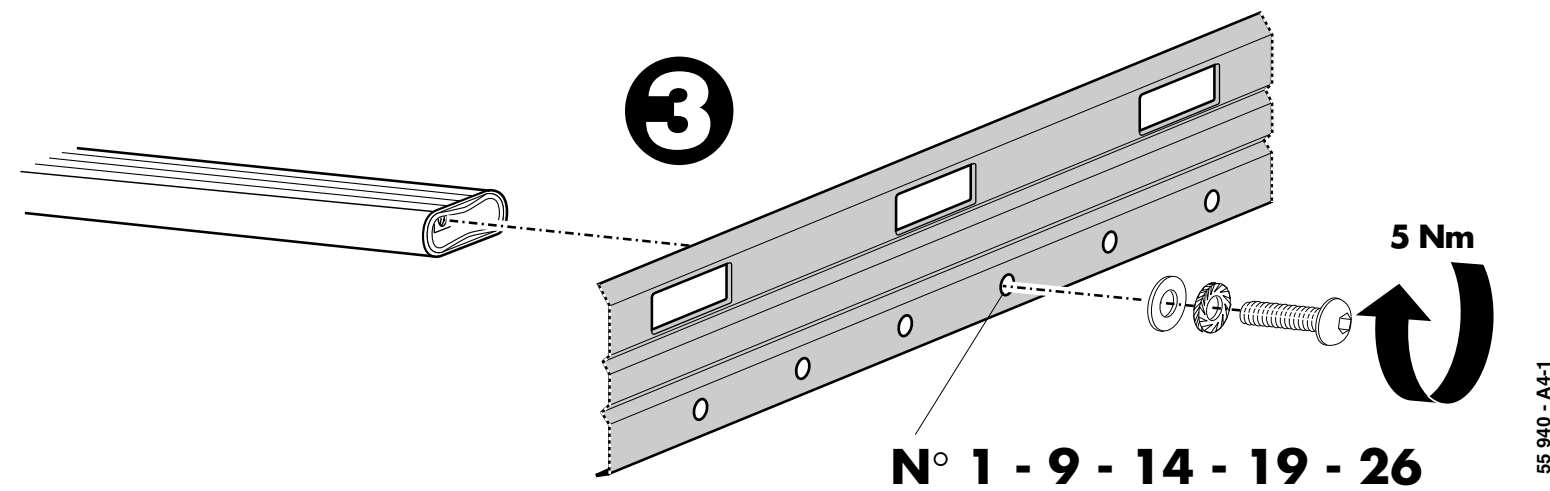

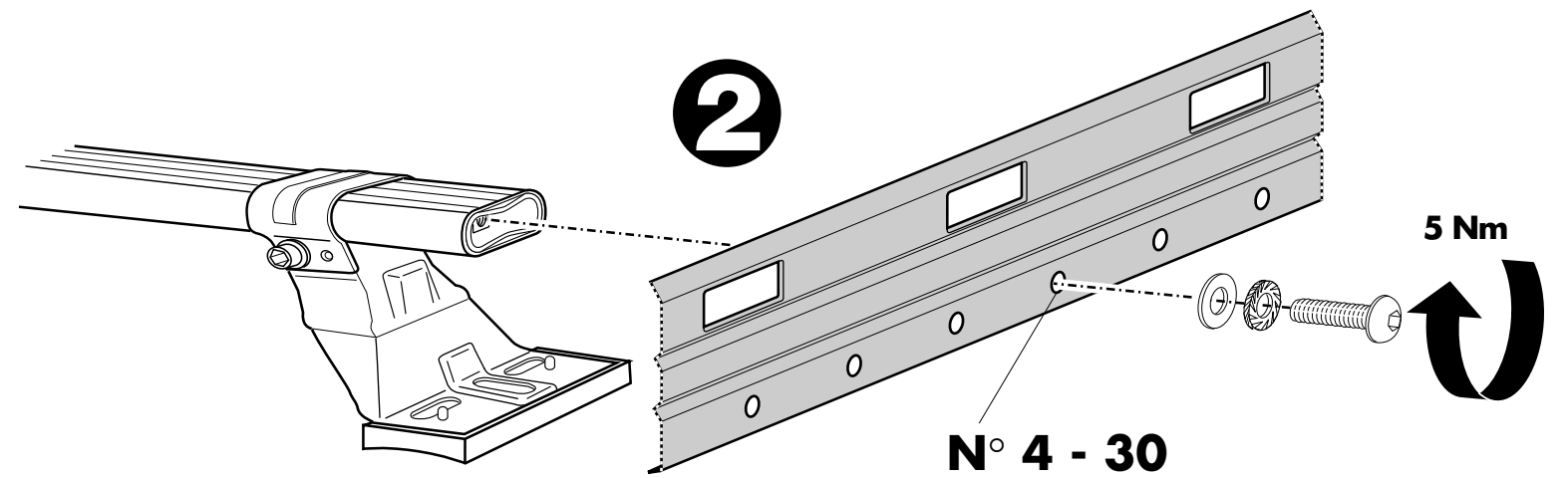
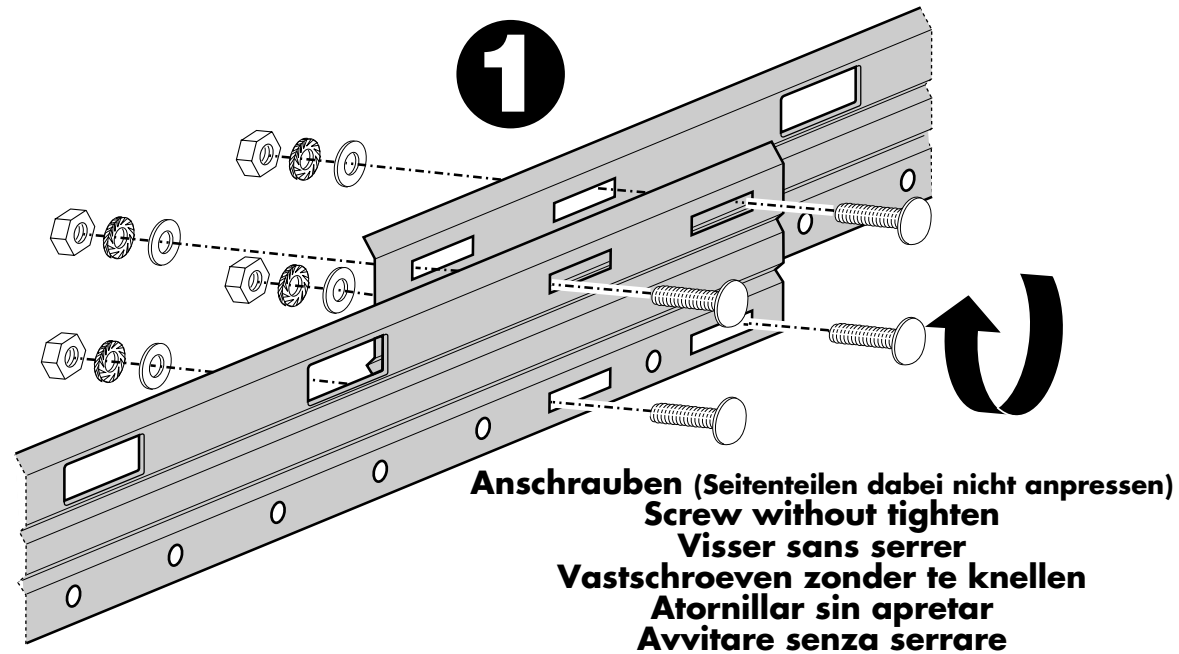
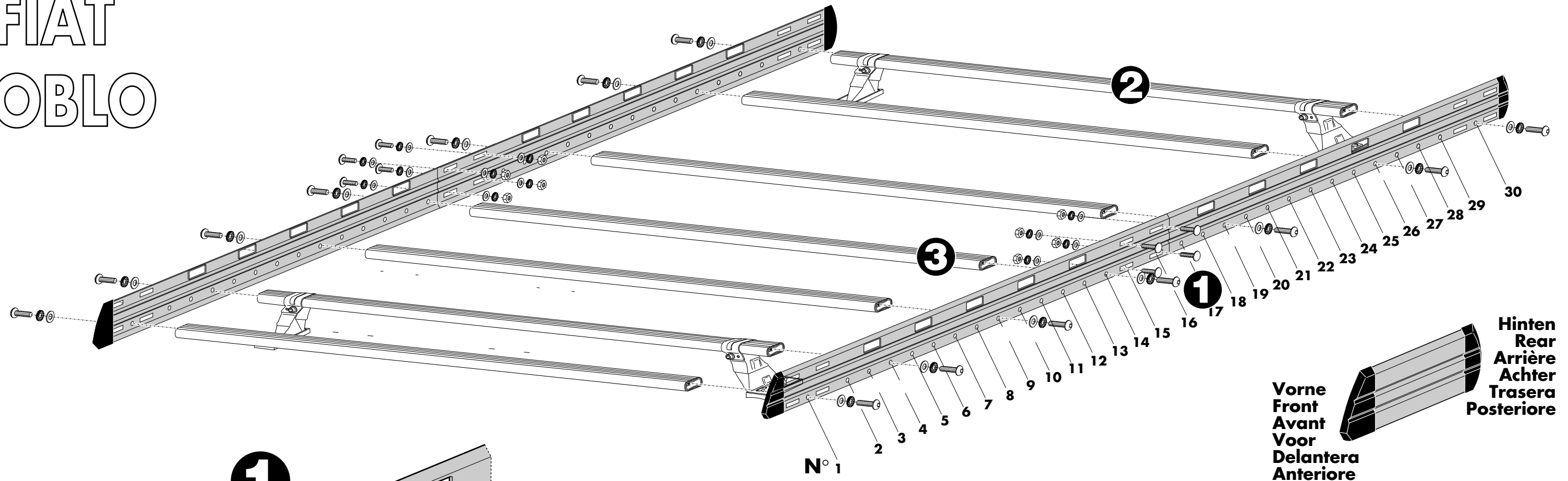
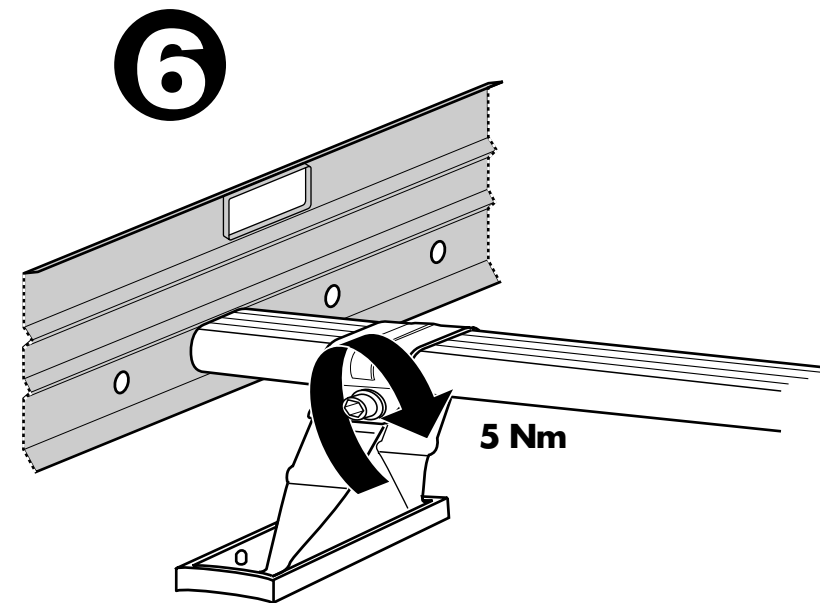
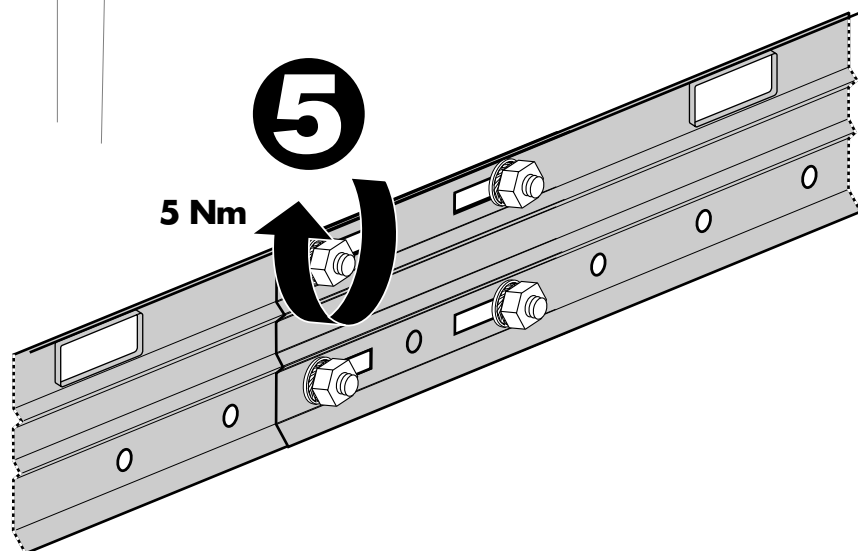
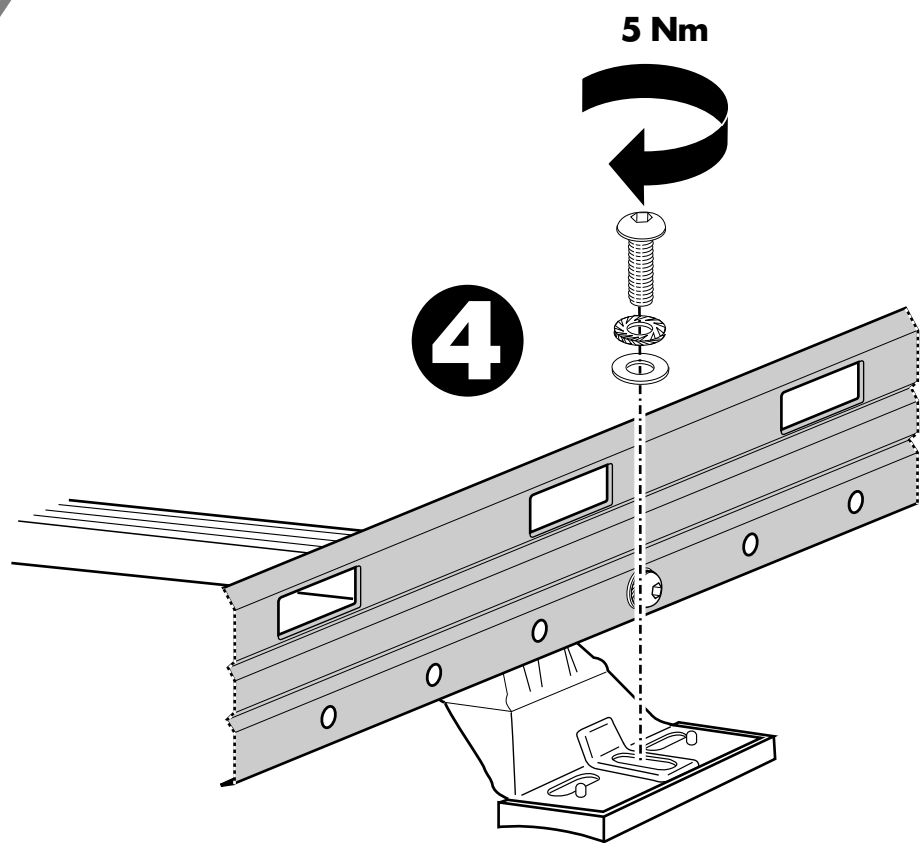
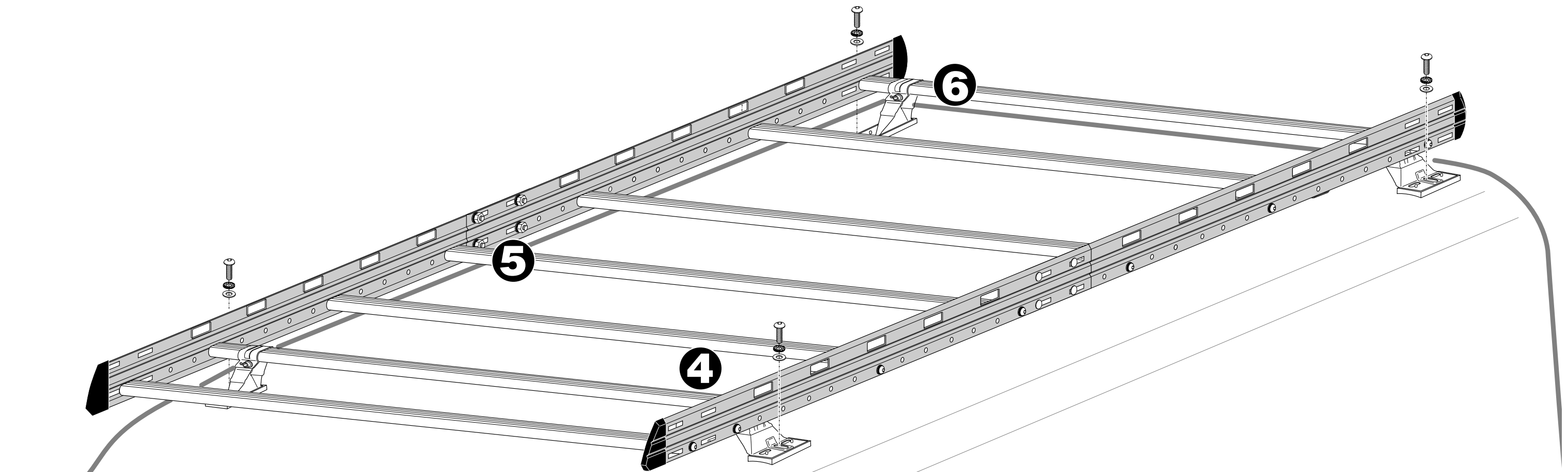

FIAT DOBLO

FORD TRANSIT CONNECT

T200

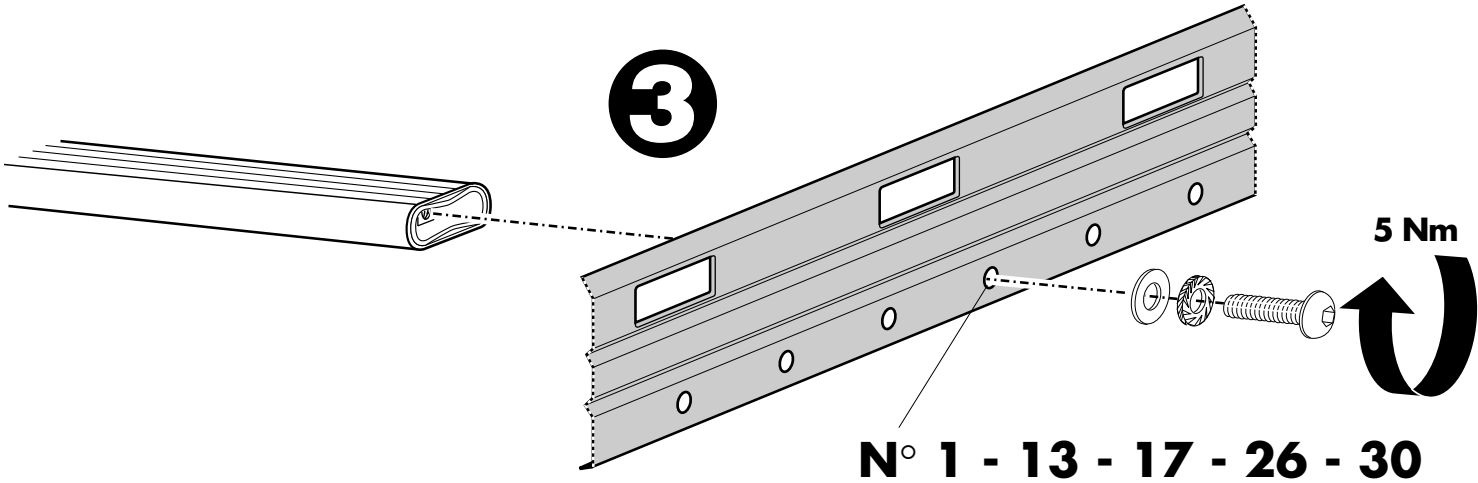
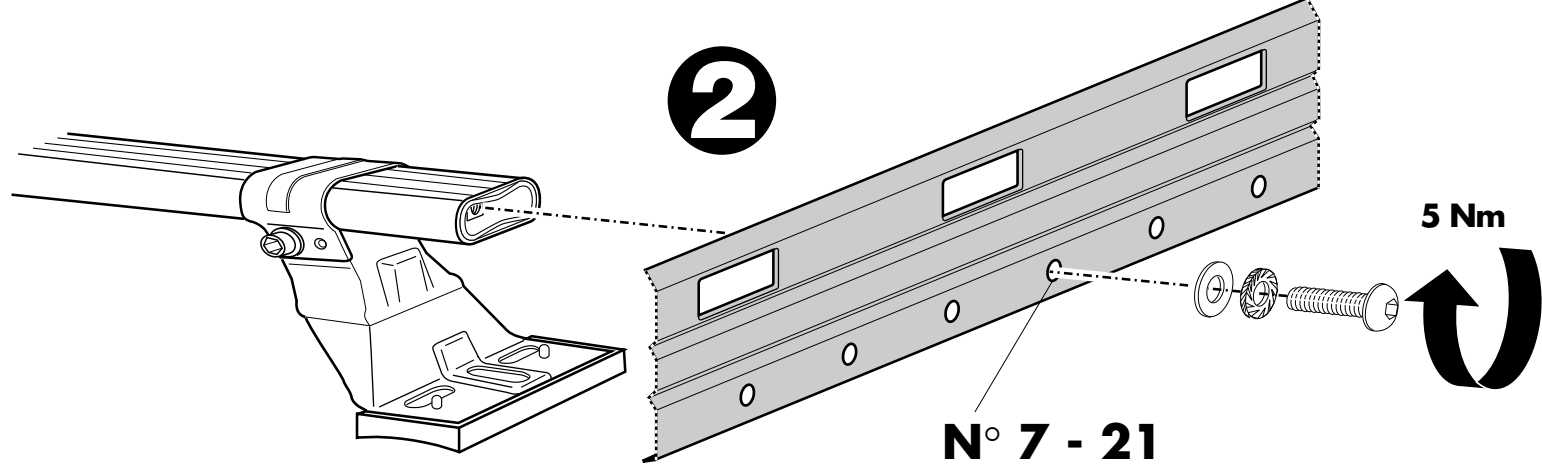
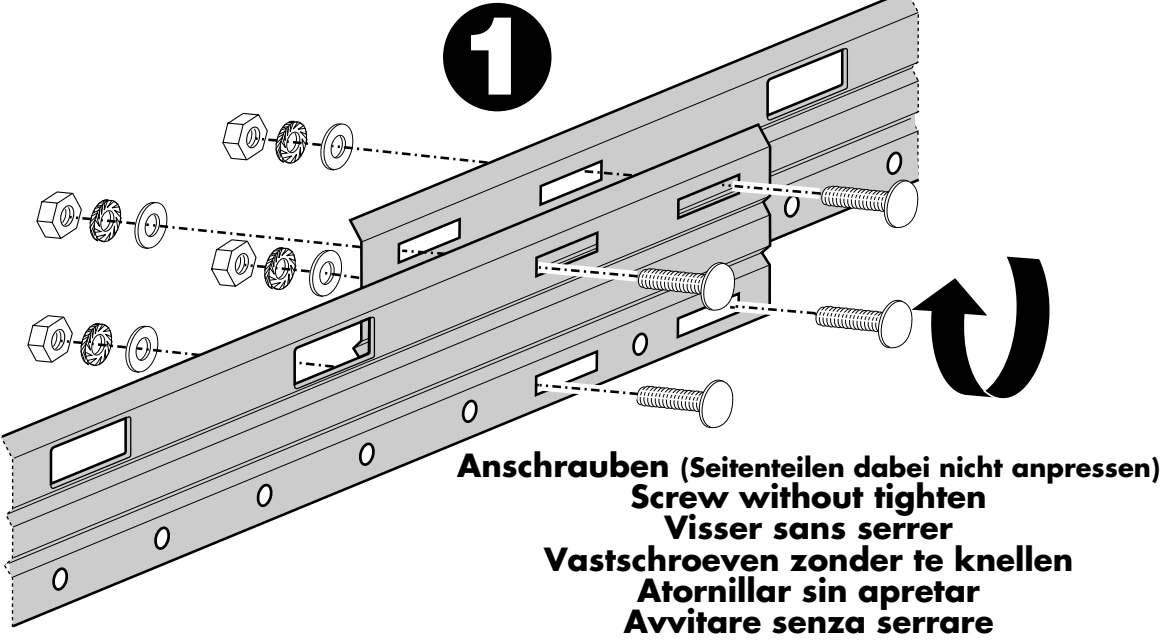
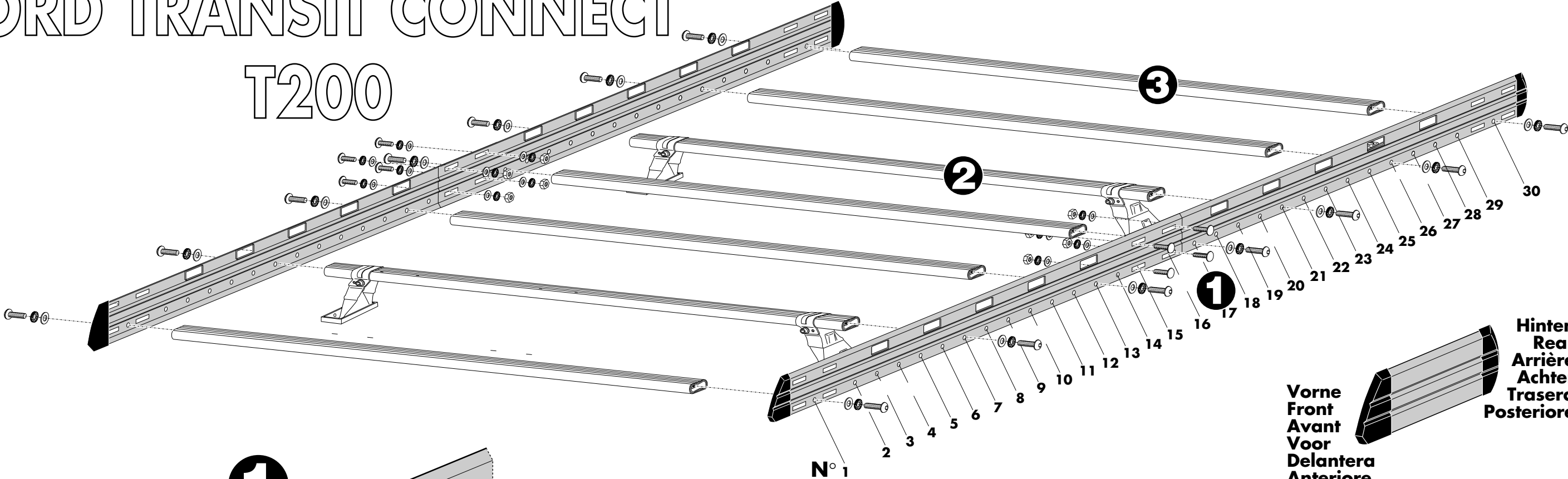

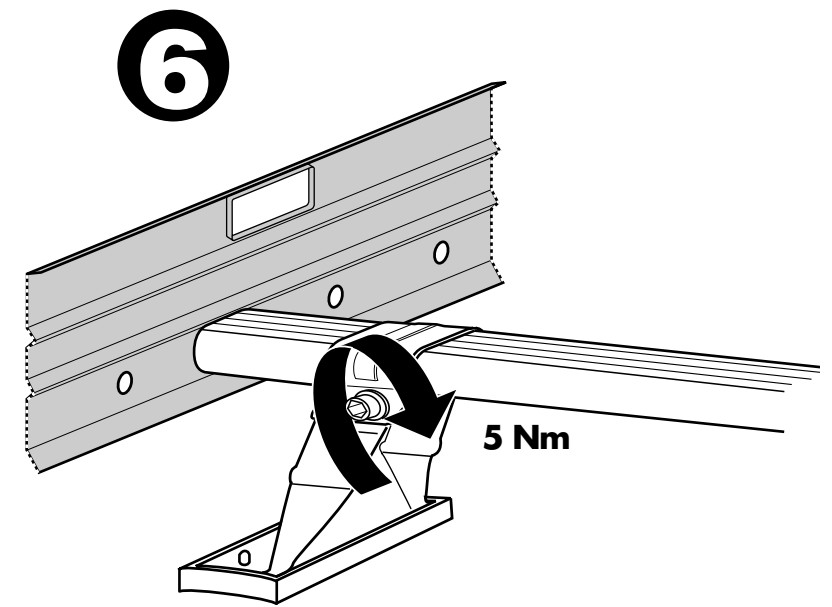
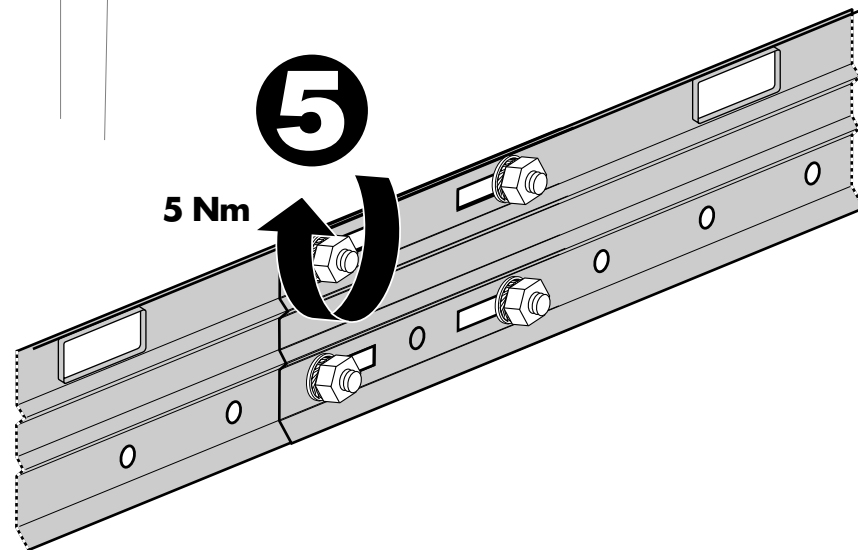
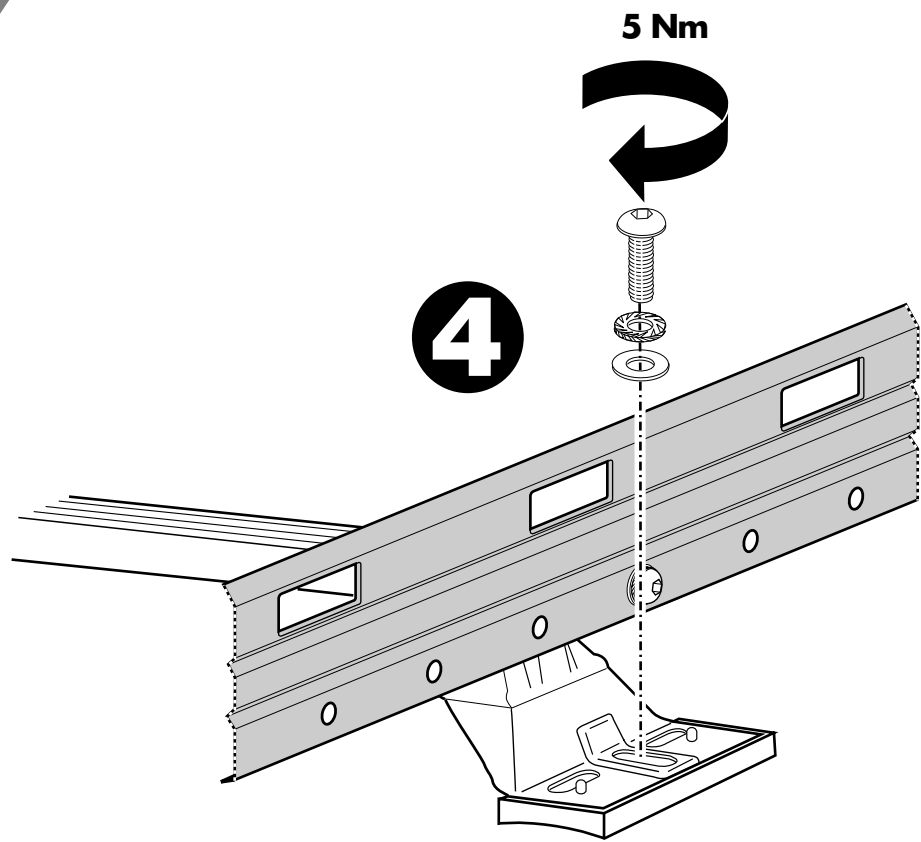
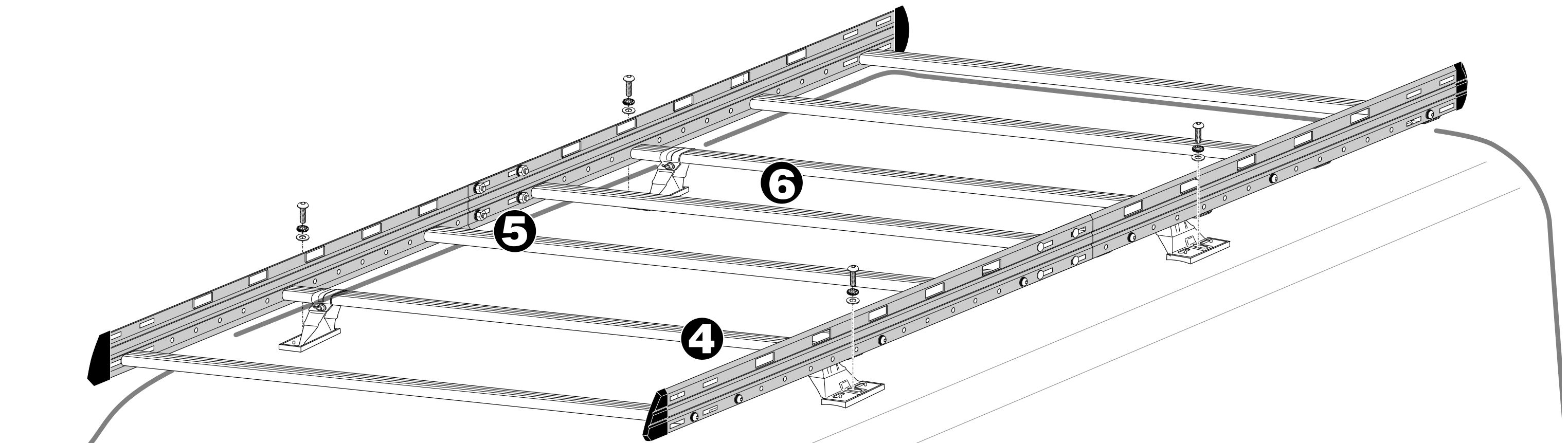

TRANSIT CONNECT T200

FORD TRANSIT CONNECT

T230

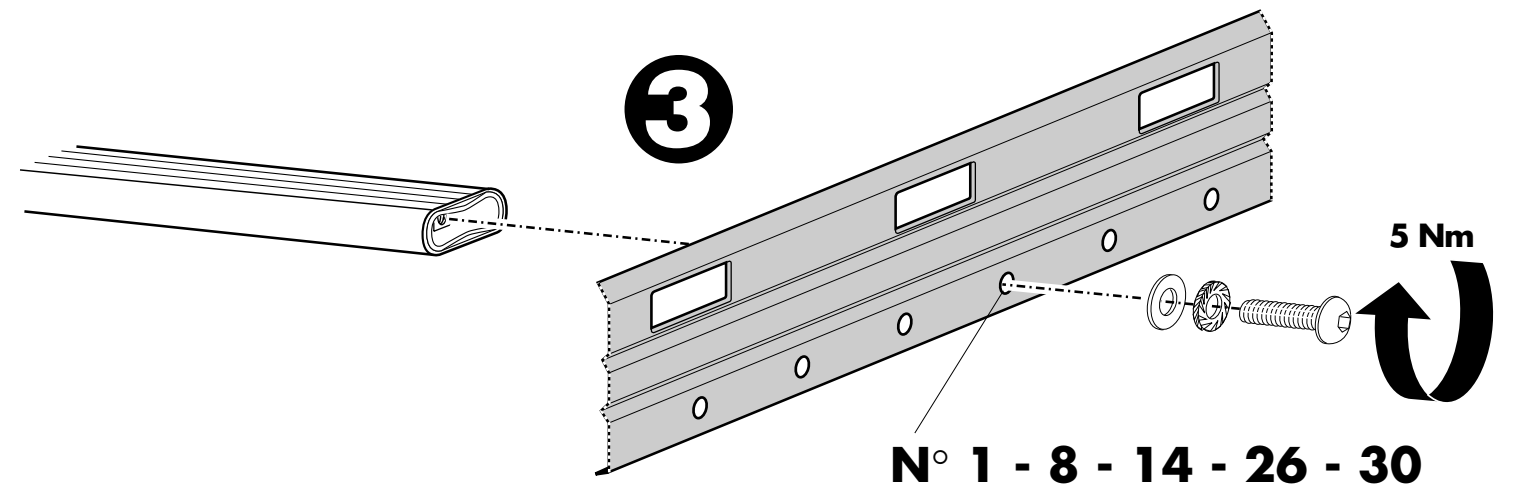
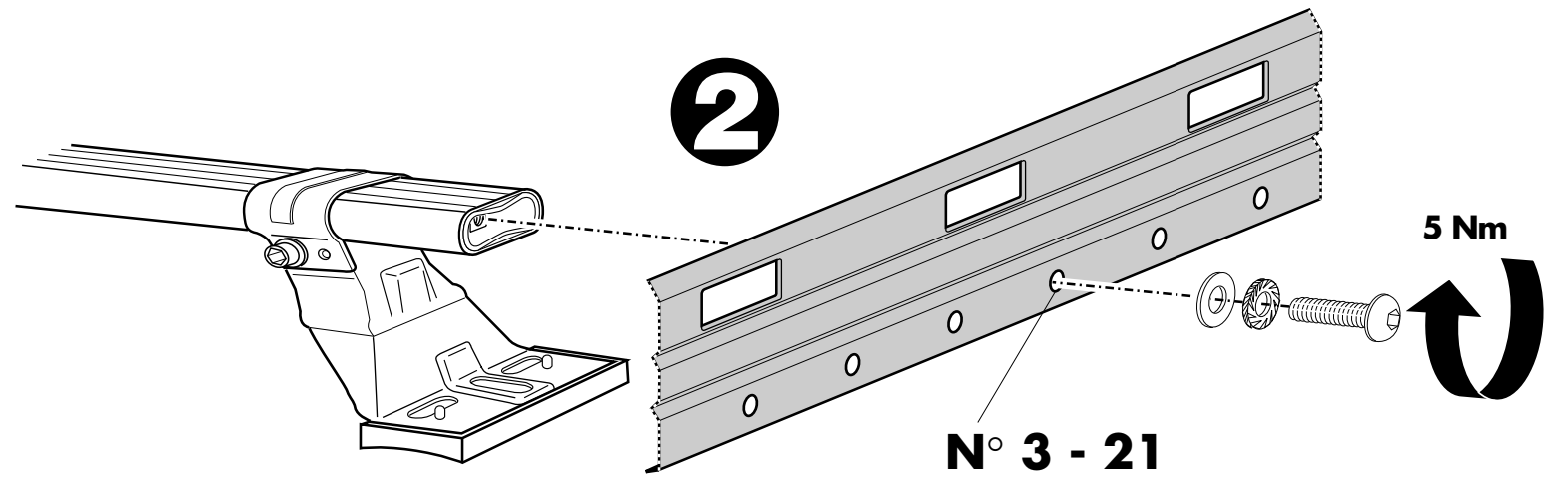
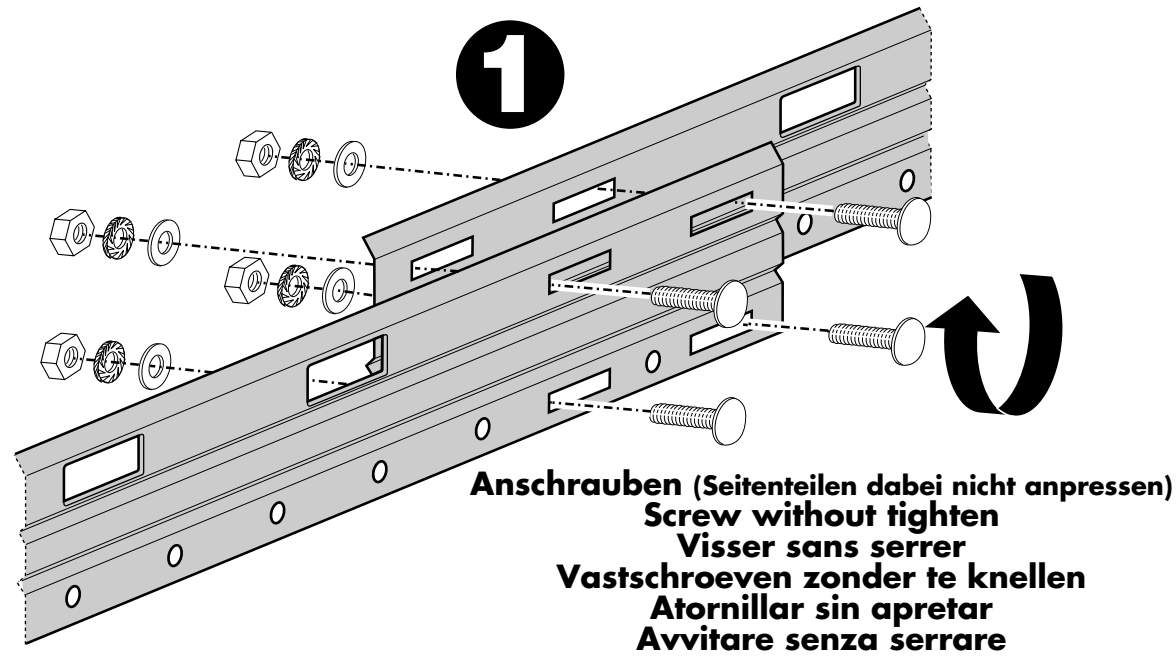
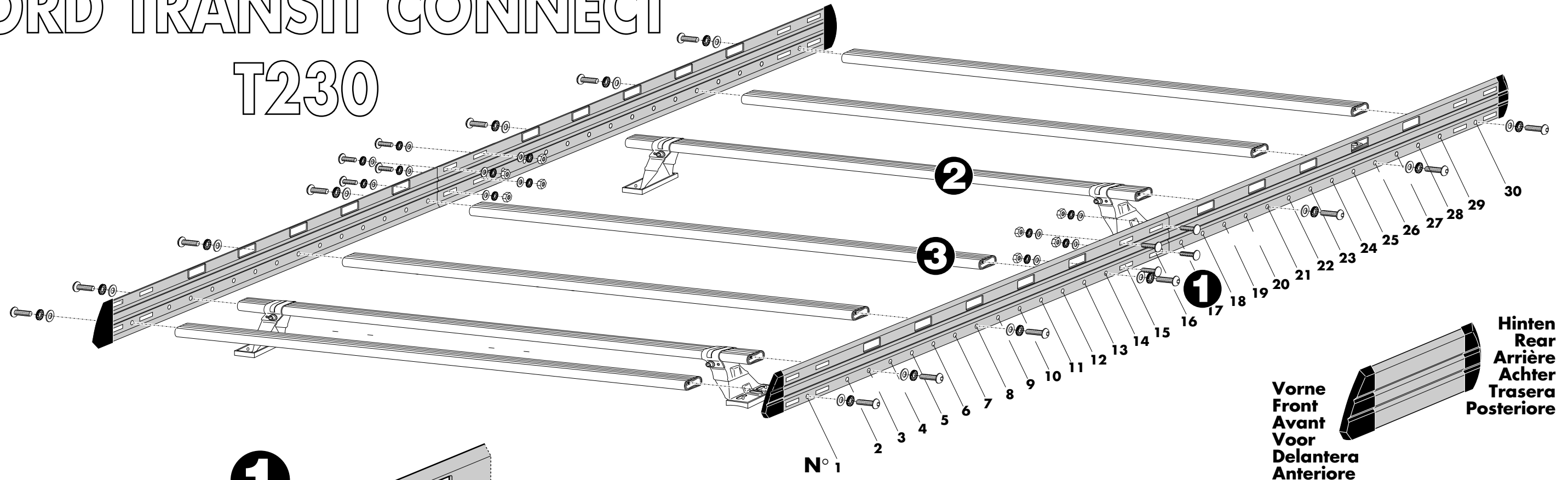

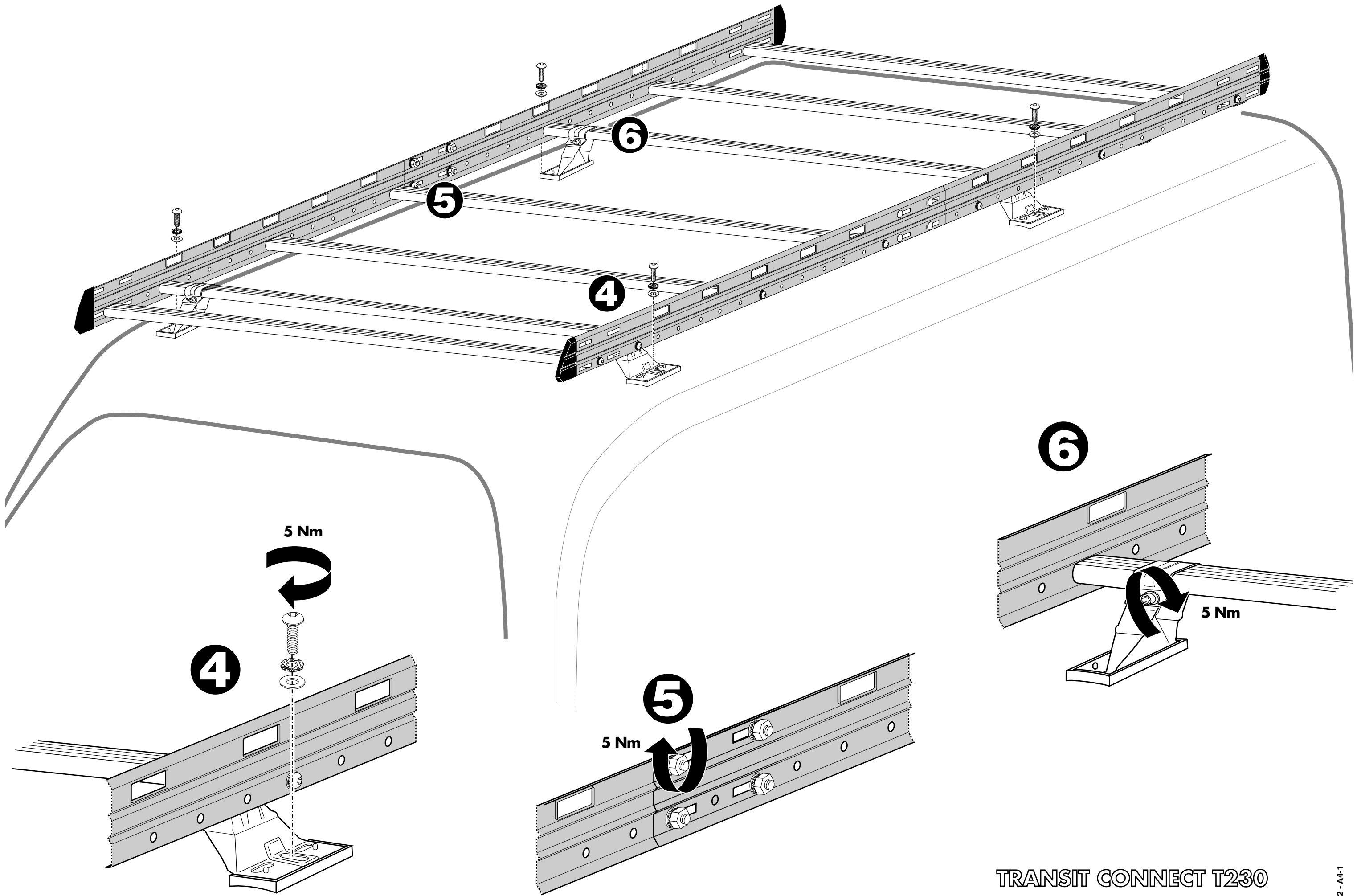

TRANSIT CONNECT T230

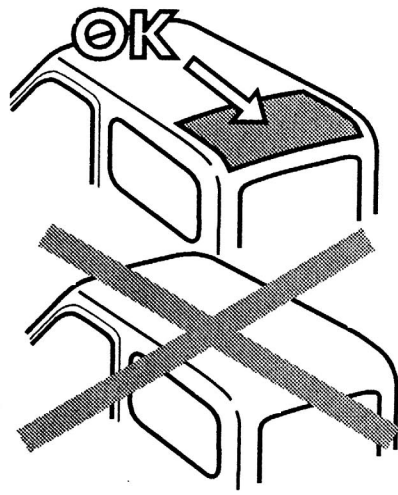

RENAULT KANGOO

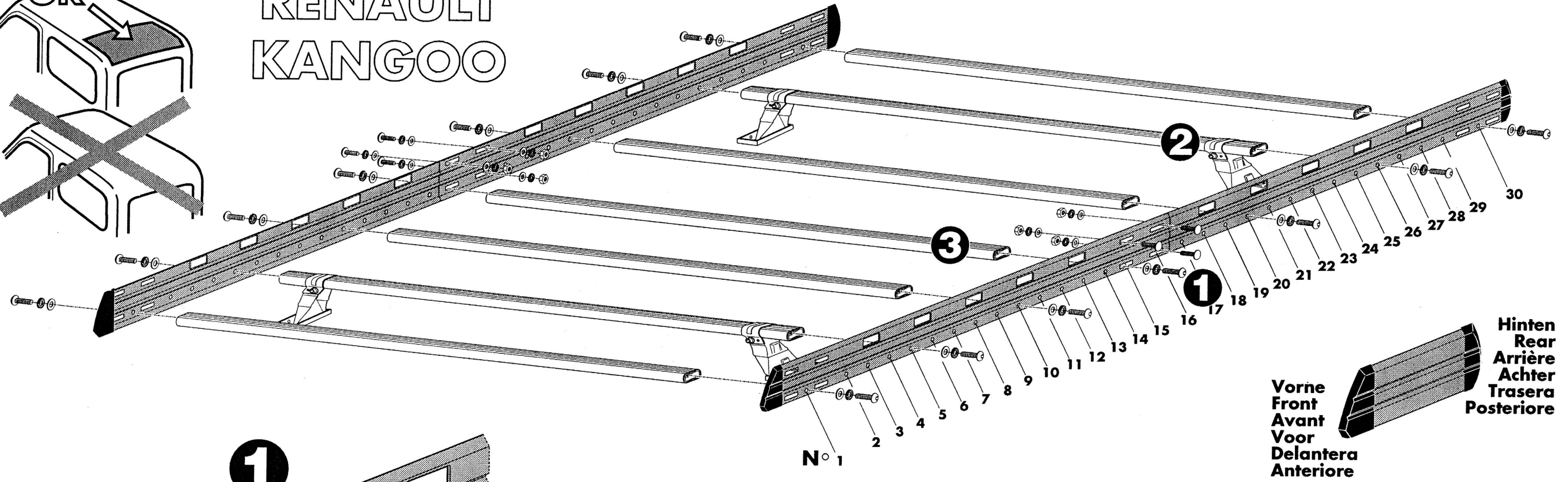

1

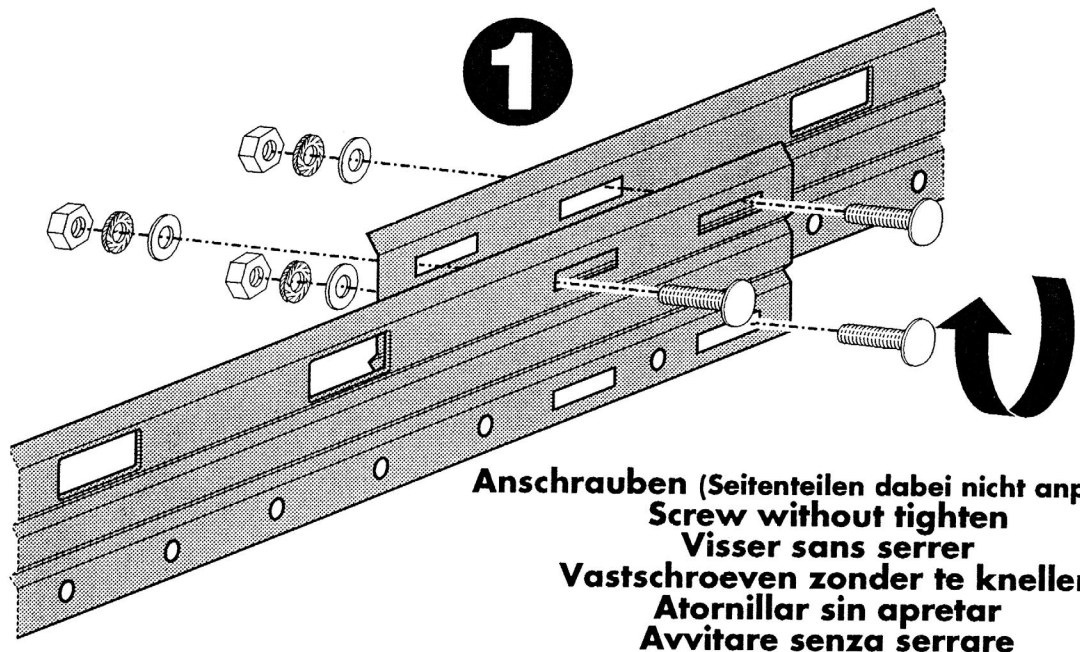

Anschrauben (Seitenteilen dabei nicht anpressen)
Screw without tighten
Visser sans serrer
Vastschroeven zonder te knellen
Atornillar sin apretar
Avvitare senza serrare

2

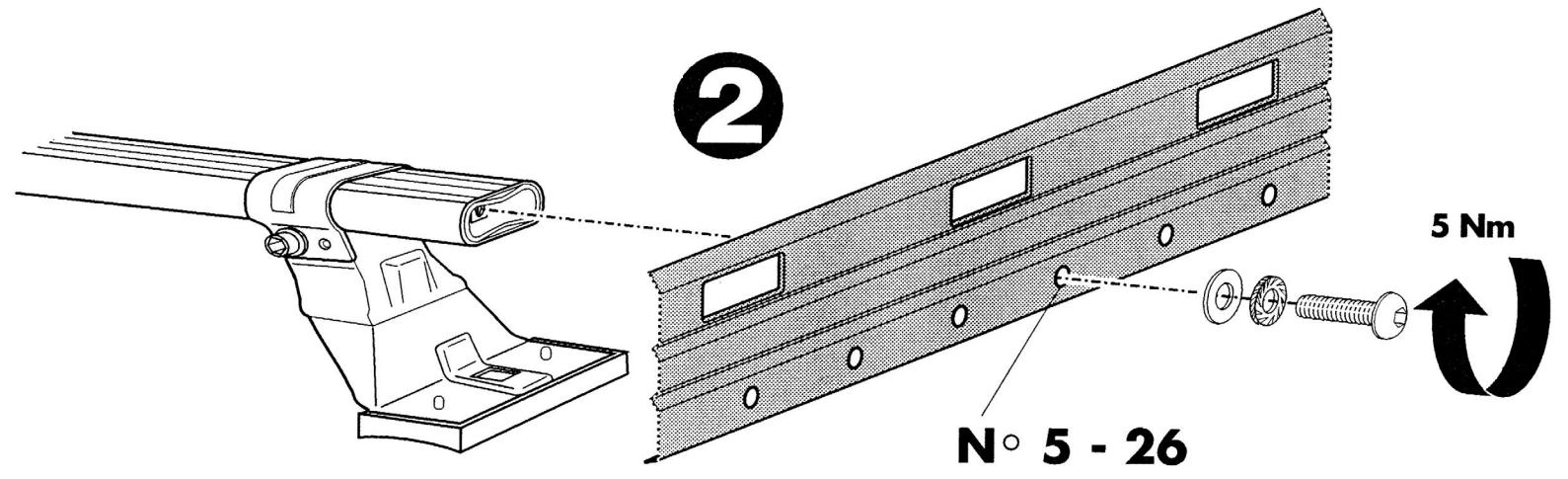

N° 5 - 26

3

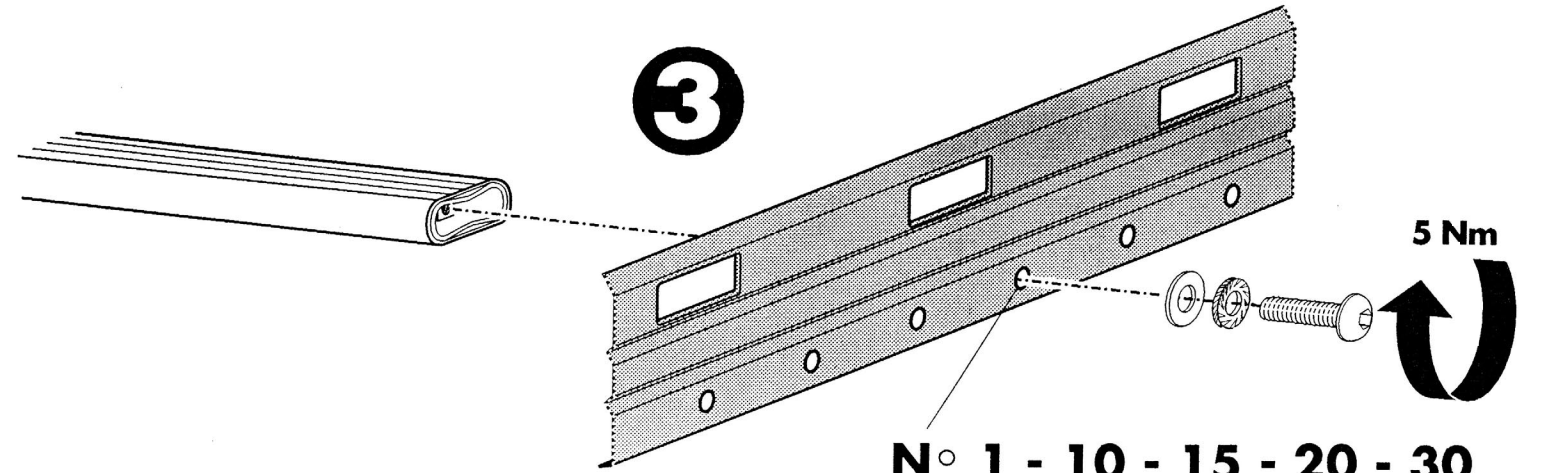

N° 1 - 10 - 15 - 20 - 30

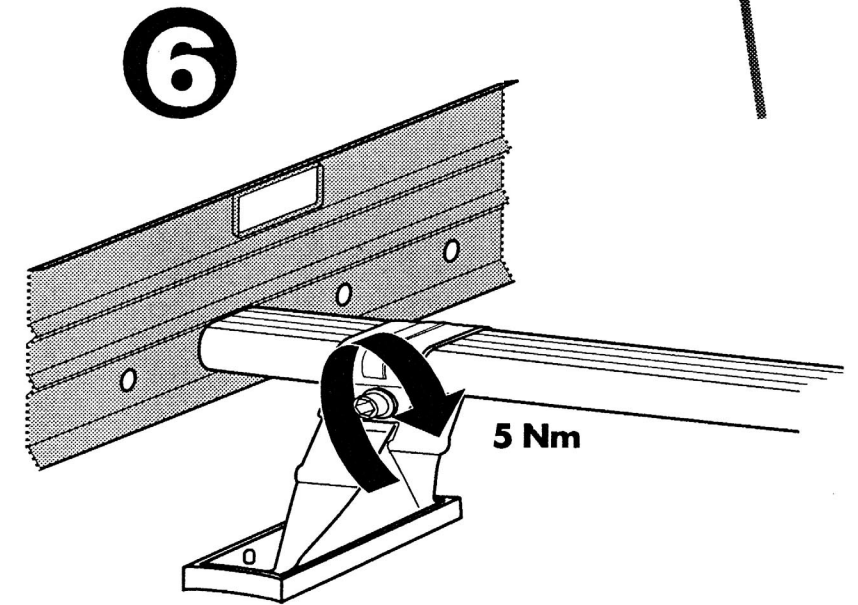
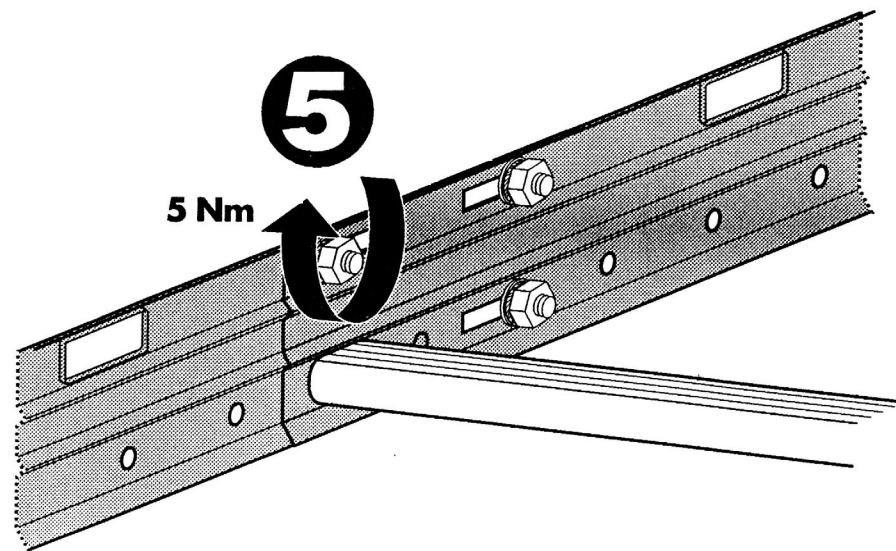
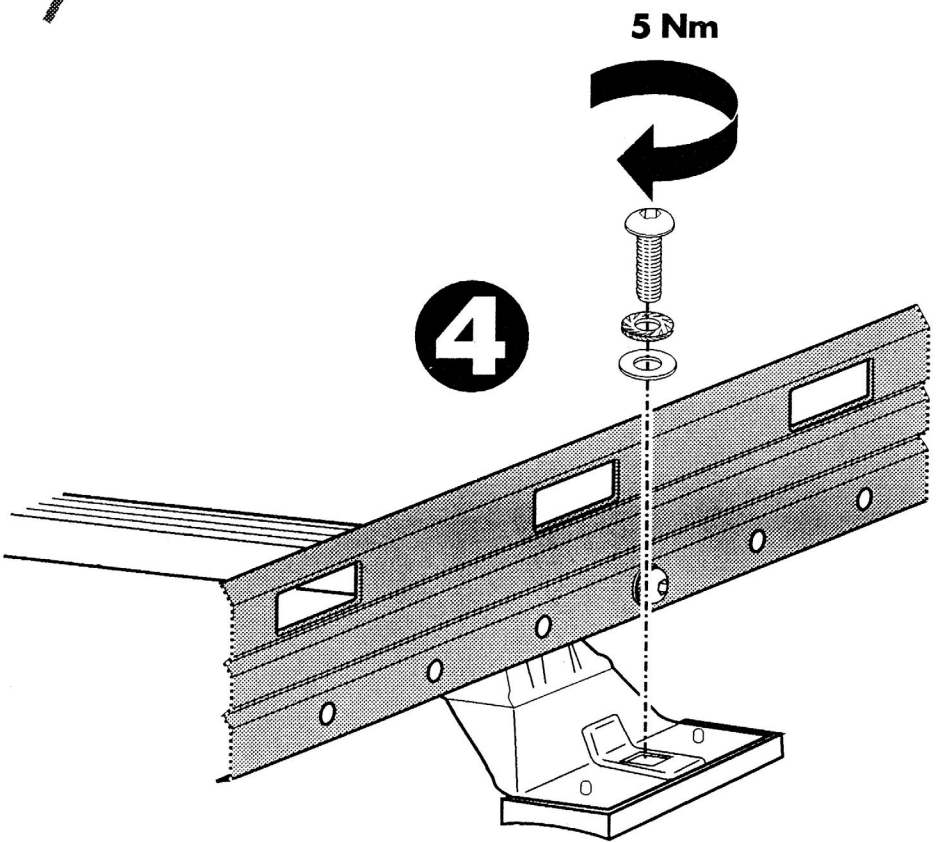
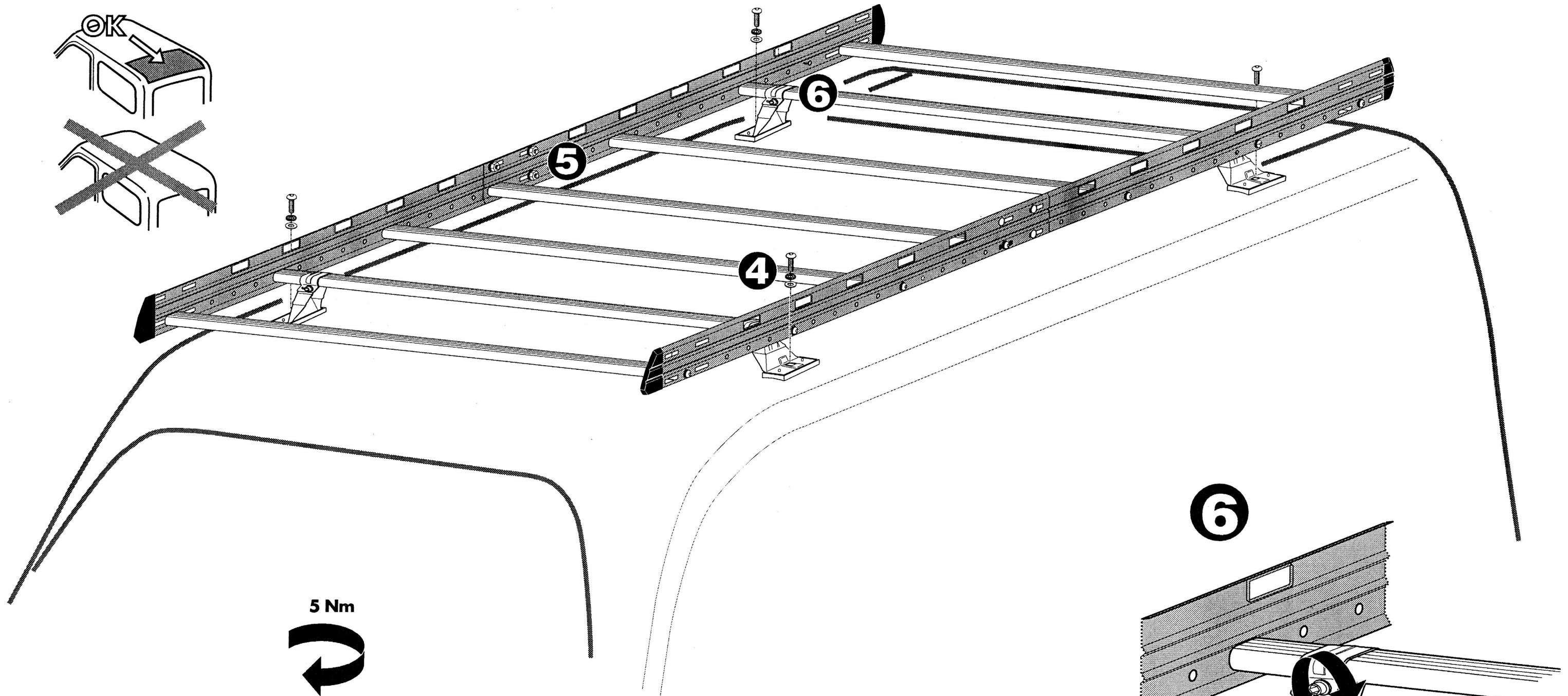
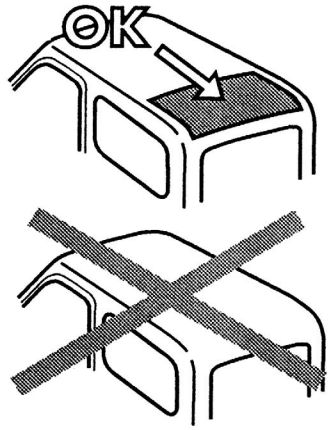

KANGOO

VW Caddy

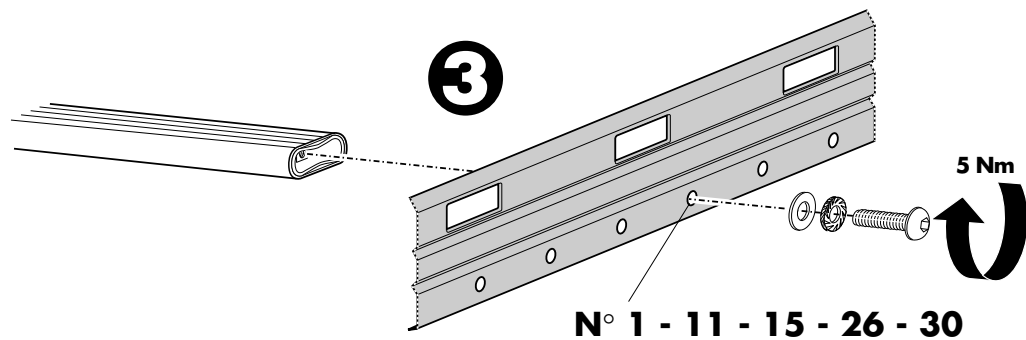
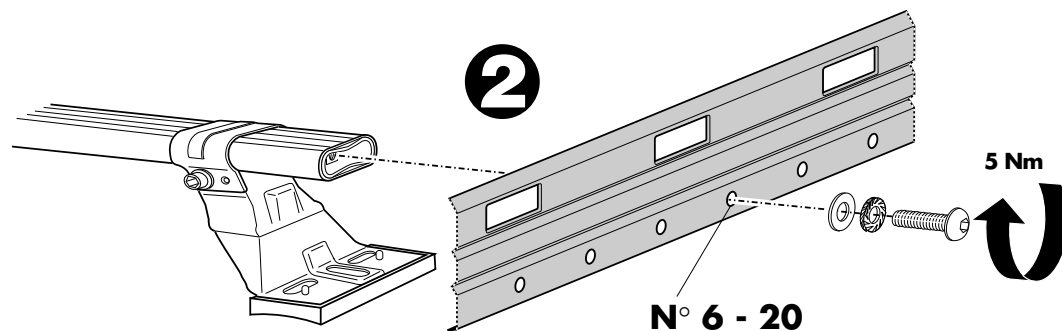
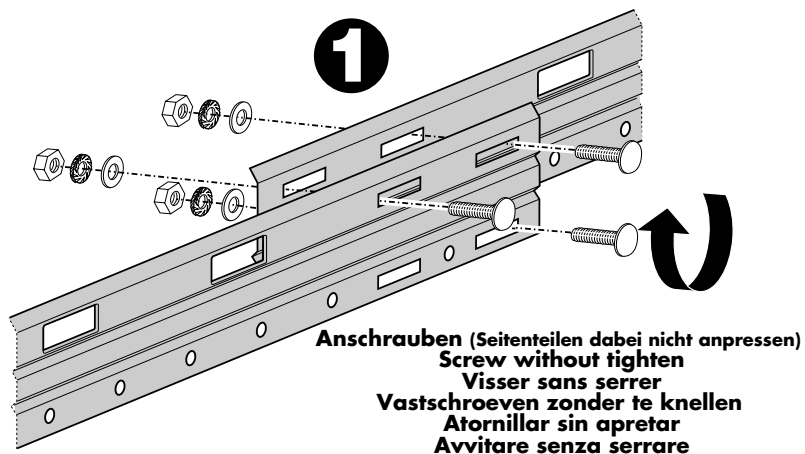
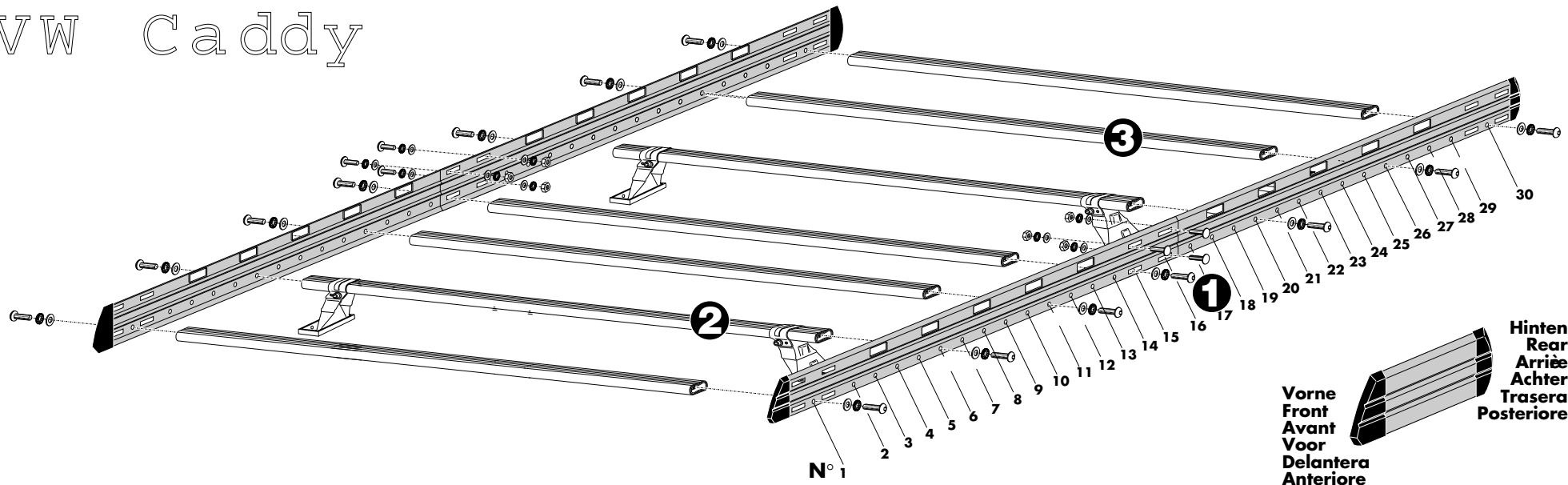

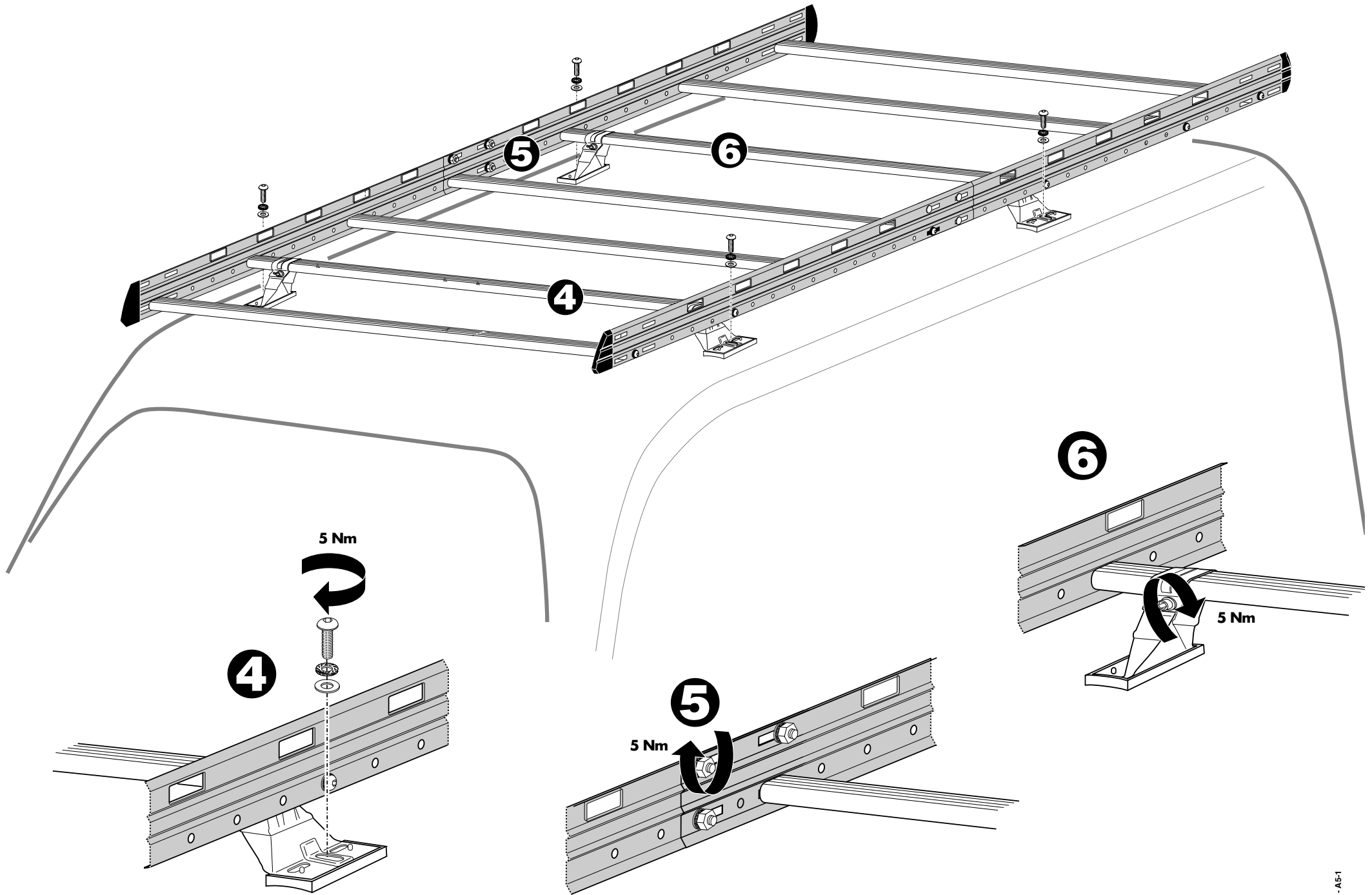

VW Caddy